

# MS THUNDER BIRD

MV THUNDER BIRD : CALL SIGN: OWDG2 IMO NO: 9318943

OWNERS: K/S THUNDER BIRD - 4220 KORSOER - DENMARK  
 PORT OF REGISTRY: KORSOER  
 FLAG: DANISH



## MAIN PARTICULARS

### CLASS

GL + 100 ASEG EQUIPPED FOR CARRIAGE OF CONTAINERS AND DANGEROUS CARGO IMO 1.1. MC AUT STRENGTHENED FOR HEAVY CARGO.  
 LAKES FITTED

### BUILDERS

XINGANG SHIPYARD, TIANJIN YARD - 07/2004

### REGISTER TONNAGE

TYPE	INTERNATIONAL
GROSS	7,002
NET	3,375

### DIMENSIONS

LENGTH OVER ALL	119.80 M
LENGTH BETWEEN PP	113.75 M
BREADTH MOULDED	20.20 M
DEPTH MOULDED	9.80 M
DRAFT FULLY LOADED SUMMER	7.59 M

### DEAD WEIGHT CAPACITIES

DEAD WEIGHT A.T.	7,821 MTS
DEAD WEIGHT C.C.	ABT. 7,200 MTS

### CONTAINER CAPACITIES

TOTAL CAPACITY 20' x 8' x 8'6"	599
HEREOF: IN CARGO HOLD	238
ON DECK	361
CAPACITY WITH AVERAGE 14 TS 377	
REEFER CONTAINERS	36

### STACKLOAD

TANKTOP	100 TS EACH 20' 120 TS EACH 40'
DECK	60 TS EACH 20' 80 TS EACH 40'

### CARGO HOLD

FITTED FOR DANGEROUS CARGO SOLAS -II-2, REG 19 DBC HOLDS  
 FITTED WITH SMOKE DETECTORS, CO2 SYSTEM, SPRINKLER

### HATCHES

HATCH NO. 1	13.01 X 15.53 + 5.85 X 10.32 M
HATCH NO. 2	52.00 X 16.10 X 10.80 M
BOXSHAPED	

### CUBIC CAPACITIES IN HOLDS

WITH TWEEN-DECK HATCH COVERS	11,069 CBM
------------------------------	------------

### CRANES

2 ELECTRO HYDRAULIC CRANES PORT SIDE 250 TS / 12 M & 100 TS / 26 M COMBINABLE UP TO 500 TS

### DECK STRENGTH

TANKTOP	16.0 TS PER M2
TWEEDECK – HOLD NO. 1	2.5 TS PER M2
TWEEDECK – HOLD NO. 2	3.0 TS PER M2
HATCH COVER	2.5 TS PER M2

### TANK CAPACITIES

FUELOIL	ABT. 717.0 TS
MGO	ABT. 91.0 TS
FRESH WATER	ABT. 141.0 TS
BALLAST WATER	ABT. 3,926.0 TS

TANK TOP

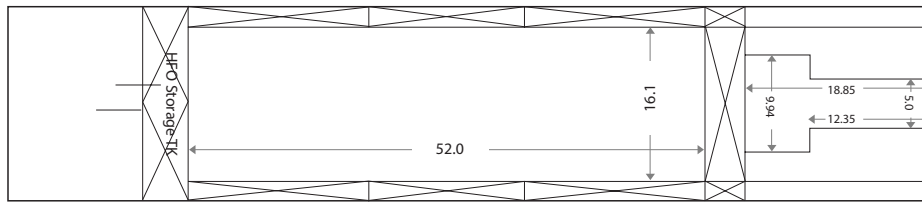

TWEEN DECK

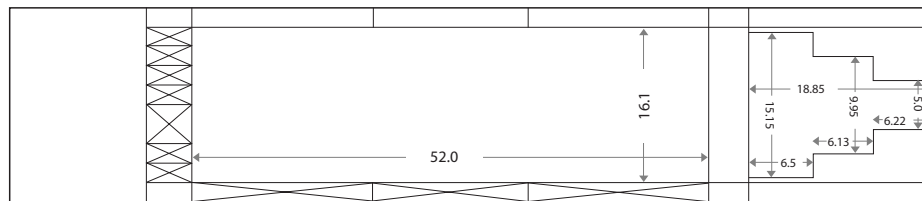

WEATHER DECK

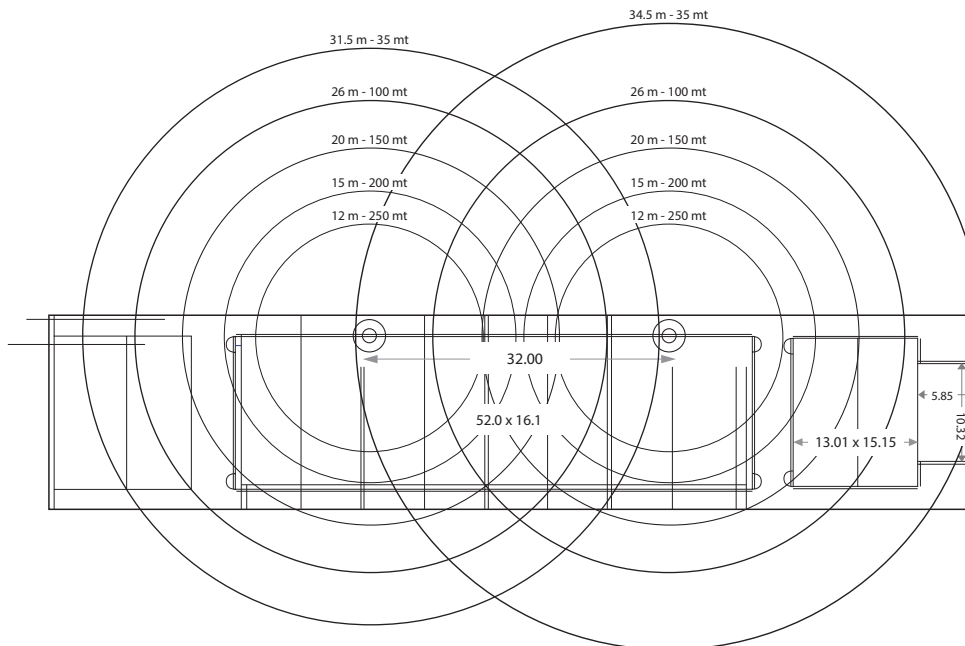

HOLD 1 HOLD 2

